



Ets BERTRAND

Machines et fournitures ostréicoles

Over 60 years of ripened expertise

**OYSTER SPAT
COLLECTING MACHINE**

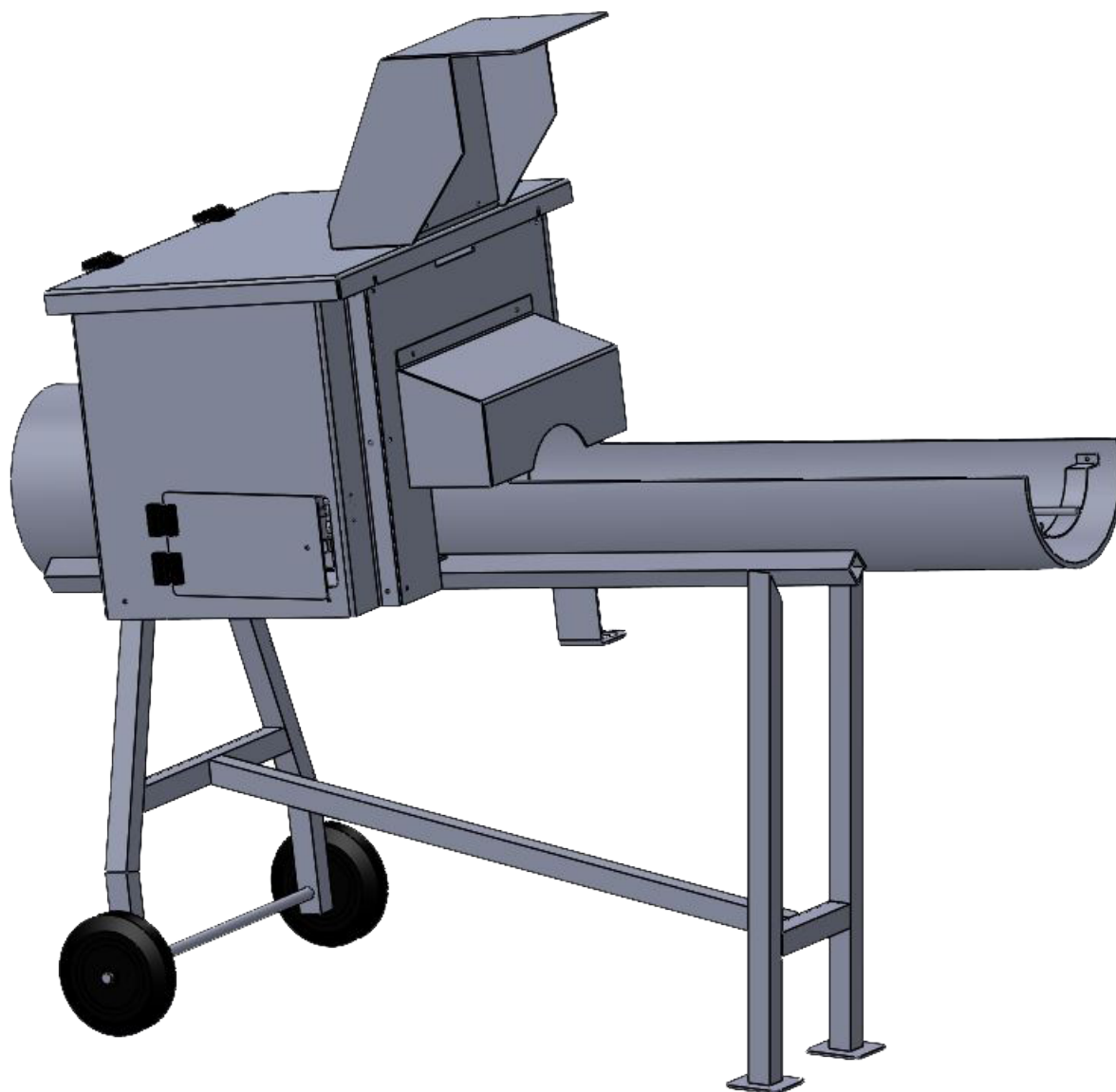

AUTOMATIQUE :

DIMENSIONS : 1890 x 780 x 1620

WEIGHT : 80 KG

ELECTRIC FEEDING : 220 V THREEPHASE

POWER : 2 x 0.37KW 3000 TR/MN

DISKS PER HOUR : ± 8000

» THE AUTOMATIC SPAT COLLECTING DEVICE (REF 4430), USER FRIENDLY AND EASY TO TRANSPORT, IS PARTICULARLY ADAPTED TO SMALL AND MIDDLE SIZE PRODUCTIONS.

» THIS DEVICE IS DESIGNED TO EASILY CAPTURE OYSTER SPAT FROM DISKS.

» THIS OPERATION USELY OCCURS WHEN BABY OYSTERS REACH 10 TO 20 MONTHS.

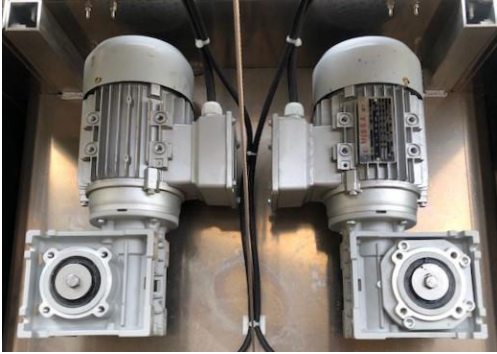

Double Reducing gear



Steel blades



Electric box with speed variator

» BLADES IN STEEL WILL SCRAPE DISK IN ORDER TO COLLECT BABY OYSTERS OF ANY SIZE.

» BABY OYSTERS ARE COLLECTED, SORTED AND THEN PACKED IN BAGS IN WICH THEY WILL CARRY ON WITH THEIR GROWTH IN SEVERAL POOLS DURING ABOUT 2 YEARS.

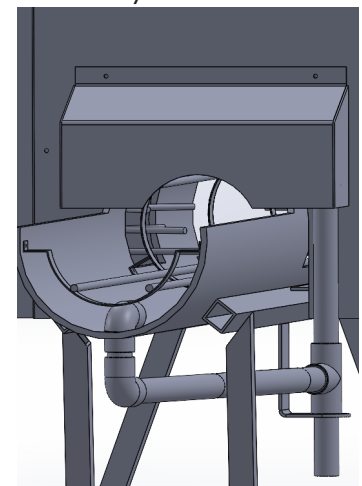

Water circuit

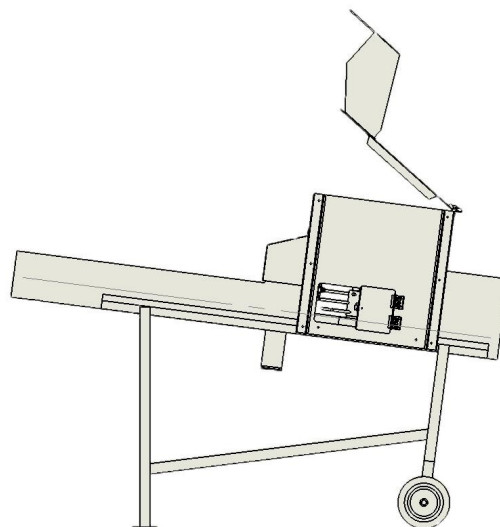
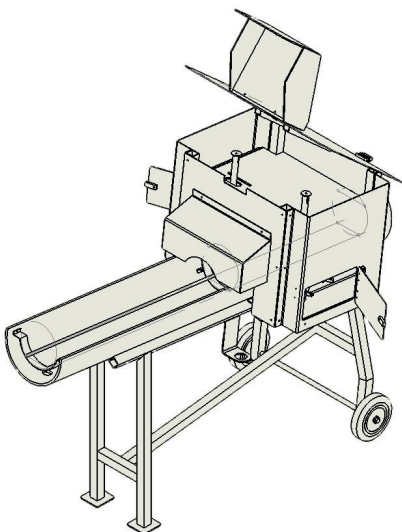

« ITS WATER SYSTEM ALLOW THE CIRCULATION OF BABY OYSTERS TILL THE END OF THE DECLUMPING »

SAS BERTRAND ROGER
La Chainade - 17320 MARENNES
☎ 05 46 85 00 36
✉ marennes@ets-bertrand.com

SAS BERTRAND ET FILS
Port Canal - 33470 GUJAN-MESTRAS
☎ 05 57 15 23 25
✉ gujan@ets-bertrand.com

www.bertrand-ostreiculture.com