

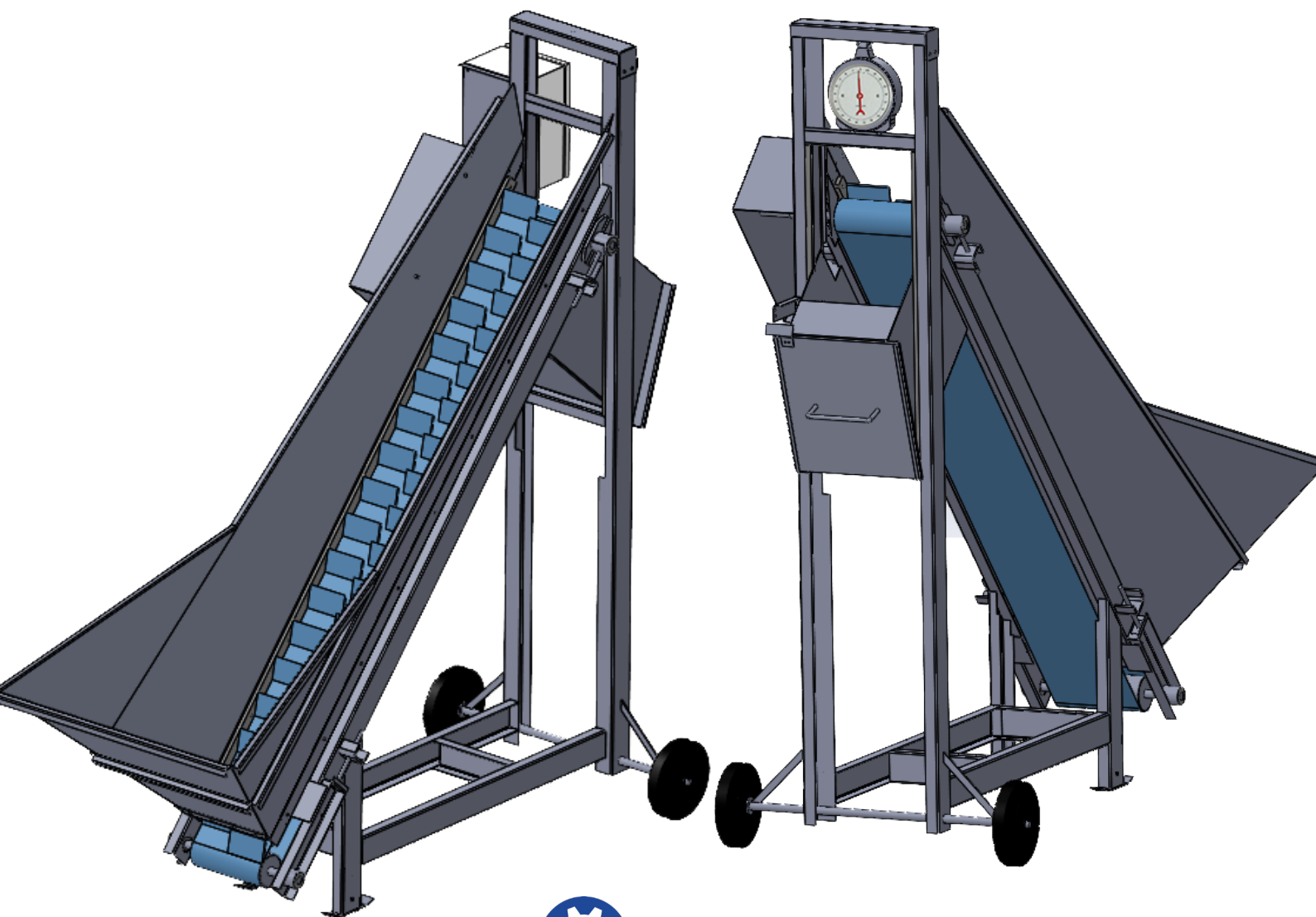

**Ets BERTRAND**  
Machines et fournitures ostrécoles

*Over 60 years of ripened expertise*

## SHELLFISH BAGGER



**DIMENSIONS : 1960x778x1982**

**WEIGHT : 60 KG**

**POWER : 380 V**

**ELECTRIC FEEDING : 220 V**

**FRAME : 316 L STAINLESS STEEL**

**PVC BELT WITH BRACKETS : 200 MM**

**2 VERSIONS : MANUAL / ÉLECTRONIC**

**LOAD CAPACITY : 0.35M<sup>3</sup>**

» THE SHELLFISH BAGGER IS AVAILABLE IN 2 VERSIONS, WHETHER WITH MANUAL SCALE (REF 4309) OR WITH ELECTRONIC SCALES (REF 4314).

» THE DEVICE IS DESIGNED TO PACK SHELLFISH AT THE END OF A GRADER BY THE SHELLS.

» A SENSOR LOCATED AT THE TRAP DOOR REACTIVATES THE RUNNING OF THE TREADMILL IMMEDIATELY AFTER EACH WEIGHING FOR A NON-STOP PRODUCTION.

---

» THANKS TO ITS 2 WHEELS, THE SHELLFISH BAGGER WILL ADAPT TO YOUR NEEDS. EASY TO USE AND MAINTAIN, THE DEVICE IS PARTICULARLY DESIGNED TO EXPORT MARKETS.

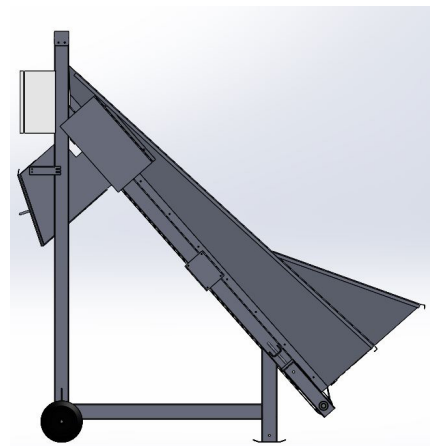

» THE VERSION WITH MANUAL SCALE OFFERS A PRECISION OF  $\pm 200$ GR AND CAN BE FITTED WITH A SPEED VARIATOR AS AN OPTION (REF 43090).

---

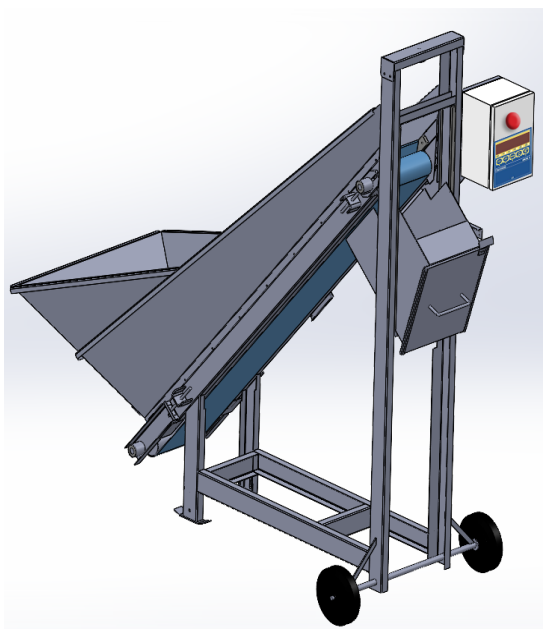

» THE ELECTRONIC VERSION IS SUPPLIED WITH DIGITAL CONTROL SCREEN, SPEED VARIATOR AND ITS PRECISION AMOUNTS TO  $\pm 120$  GR.

---

» THE TREADMILL WITH BRACKETS ENABLES AN UNIFORM RAISING OF SHELLS FOR A PRECISE WEIGHING.

---

» THE ELECTRONIC VERSION IS FITTED WITH A SPEED VARIATOR.

---

« THANKS TO ITS PRECISION AND VARIOUS PROGRAMS, THE ELECTRONIC VERSION OF THE SHELLFISH BAGGER WILL OPTIMIZE YOUR PRODUCTION »

» THE SCALE SCREEN INDICATES A REALTIME WEIGHT OF SHELLS IN THE HOPPER.

---

» THE DEVICE OFFERS THE POSSIBILITY TO INDICATE THE WEIGHT IN POUNDS, GRAMS AND KILOGRAMS.



Digital screen

SAS BERTRAND ROGER  
La Chainade - 17320 MARENNES  
☎ 05 46 85 00 36  
✉ marennes@ets-bertrand.com

SAS BERTRAND ET FILS  
Port Canal - 33470 GUJAN-MESTRAS  
☎ 05 57 15 23 25  
✉ gujan@ets-bertrand.com

[www.bertrand-ostreiculture.com](http://www.bertrand-ostreiculture.com)