



Ets BERTRAND

Machines et fournitures ostrécoles

Over 60 years of ripened expertise

**STANDARD FLAT
WASHER 2023**

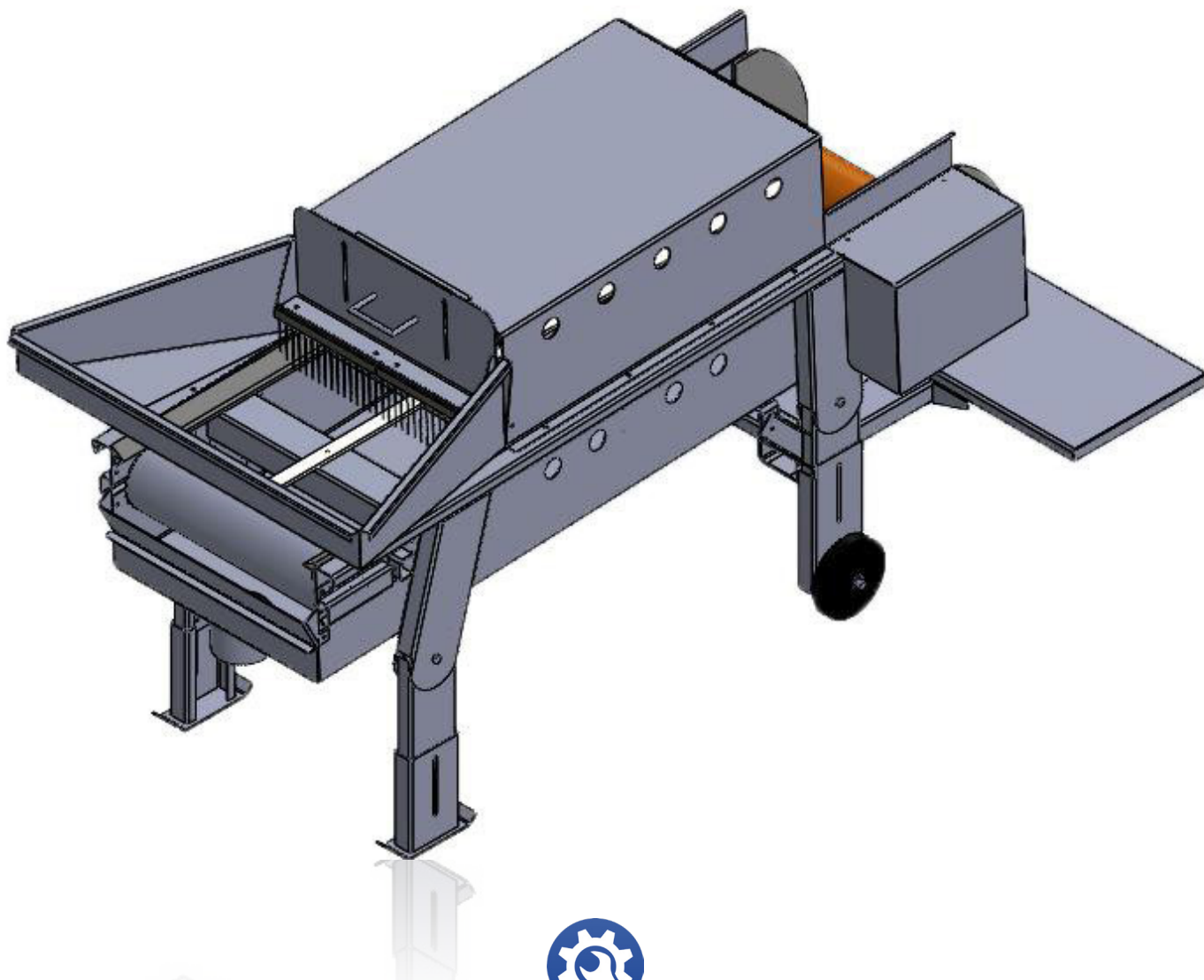

DIMENSIONS : 2320x1120x1380

DIMENSIONS W/OPTION: 2560x1500x1380

WEIGHT : 130 KG

ELECTRIC FEEDING : 220 TO 240 V

PUMP : 4 TO 10 HP

CAPACITY : ± 1 TON/HOUR

ALUMINIUM THICKNESS : 3 MM

OPTION : SHELF

» THE STANDARD WASHER IN ALUMINIUM 2023 IS ONE OF OUR LEADER EQUIPMENT, RELIABLE AND EASY TO MAINTAIN.

» THIS EQUIPMENT, DESIGNED TO THE CLEANING OF OYSTERS, IS FITTED WITH A SYSTEM OF A WASHING RAMP CONSISTING IN 9 NOZZLES LOCATED ABOVE AND UNDER OYESTERS.

» THIS SYSTEM ENSURES A PERFECT CLEANING OF OYSTERS IN BULK OR BAGS THANKS TO A BROOM RUBBING SHELLS TO REMOVE MOST OF THE DIRT BEFORE THEIR WASHING.

» THANKS TO ITS BRAND NEW ARTICULATED FEET AND ITS ADJUSTABLE HEIGHT UP TO 150MM OFFERS THE STANDARD FLAT WASHER 2023, 3 DIFFERENT WORKSTATION POSITIONS ADAPTING TO MOST PEOPLE SIZES, REDUCING THE RISKS OF MUSCULOSKELETAL ISSUES :

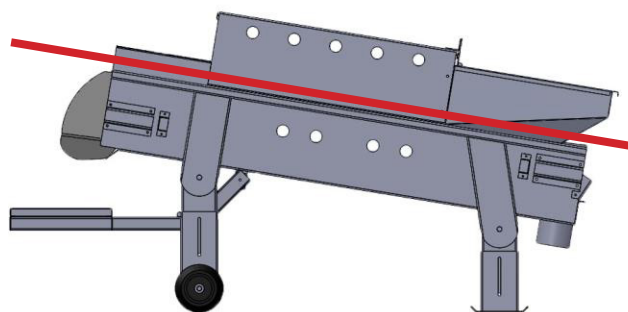

Position 2 - Multipurpose

» A WATERPROOF ELECTRIC BOX FITTED WITH A SPEED VARIATOR, AVAILABLE AS AN OPTION (REF 043080), ALLOWS THE REGULATION OF THE SPEED OF CLEANING OF OYSTERS.

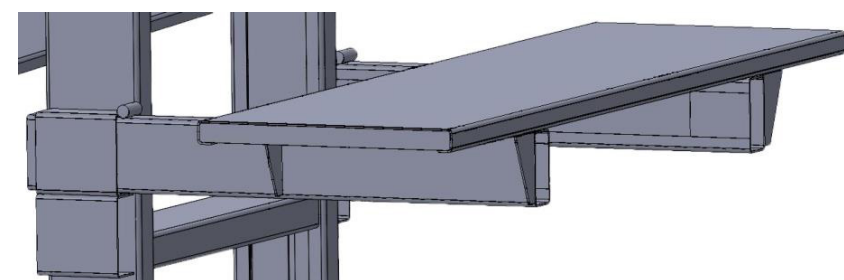

Shelf

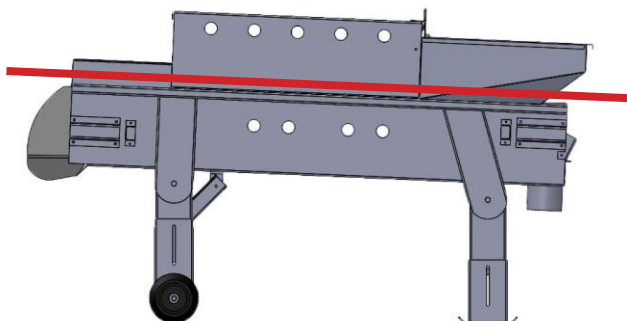

Position 1 - The passage of oysters in bulk or bags

- POSITION 1 AT 2,5°
- POSITION 2 AT 9°
- POSITION 3 AT 16°

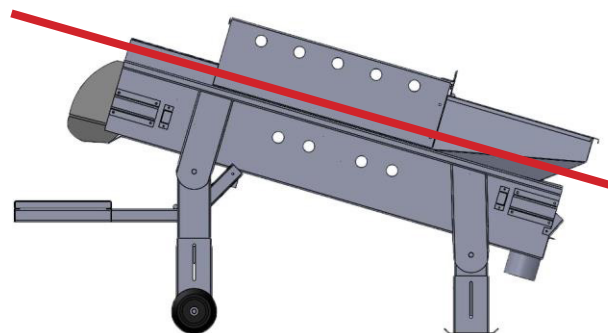

Position 3 - Passage of oysters in bulk

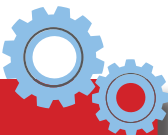

« THE SHELF OPTION WILL OPTIMIZE THE WORK STATION, REDUCING THE NEEDS IN LABOUR »

SAS BERTRAND ROGER
La Chainade - 17320 MARENNES
☎ 05 46 85 00 36
✉ marennes@ets-bertrand.com

SAS BERTRAND ET FILS
Port Canal - 33470 GUJAN-MESTRAS
☎ 05 57 15 23 25
✉ gujan@ets-bertrand.com

www.bertrand-ostreiculture.com